

LOCKING BLOCK

IMPORTANT INFORMATION

- It is vital that you follow the correct fitting procedure and tighten all fixings correctly
- If you are unsure of the correct fitting process please consult your Brompton dealer or Brompton Customer Service support@brompton.co.uk

Fig. 1

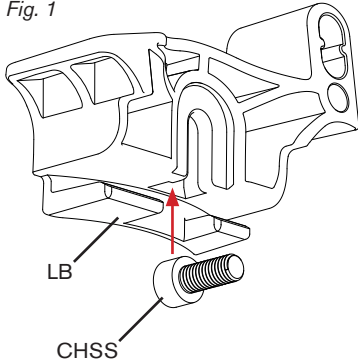

ASSEMBLY

To assemble the locking block LB, first insert the head of the M5x12 cap head socket screw CHSS into the recess in the back of the LB (fig. 1). Then insert the CHSS into the chain stay plate insert CSPI (fig. 2), and secure using a 4mm hex key. Screw in until it reaches a stop, and then start with the adjustments.

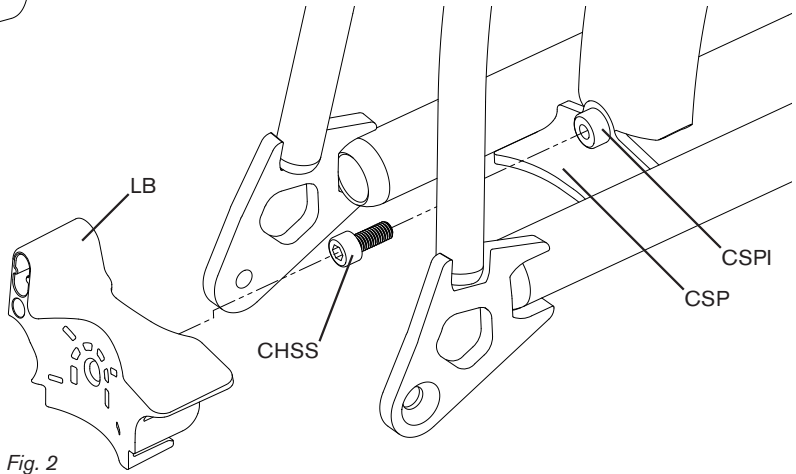

Fig. 2

ADJUSTMENT

When you pick up the folded bike, the rear wheel cannot unfold because the LB contacts the seatpost SP to stop the rear frame from moving. The LB can be adjusted to obtain the correct gap between itself and the SP. If the gap is too small the post will catch on it when folding the bike, too large and the folded bike may partially unfold when picked up.

It is easiest to make adjustments to the LB with the bike fully folded with the seatpost raised. When the seatpost is raised, make sure it is locked in place using the seat clamp.

To decrease the gap between the LB and the SP (fig. 3), using a 4mm hex key, unscrew the CHSS half a turn at a time and then lower the seatpost to check if it has clearance. If the gap is still too wide, unscrew another half turn, and check the seat post again. Repeat this process until the correct size gap is obtained.

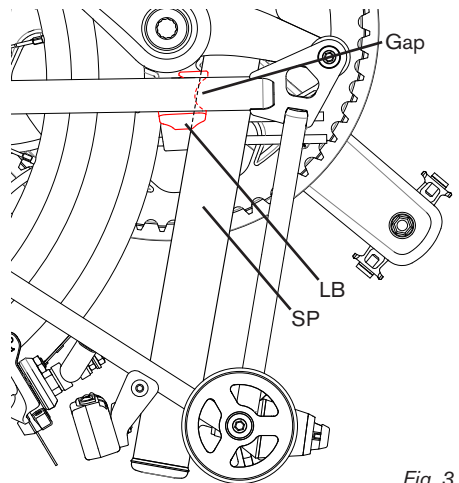

Fig. 3

PUSHING/PULLING THE BIKE WHILST FOLDED

The bike can be pushed/pulled along whilst folded, as an alternative to picking up and carrying the bike. In the folded position, raise the saddle until the bottom of the seatpost comes into contact with the locking block (fig. 4). Because the locking block still contacts the seatpost, the bike is still secured in the folding position, but with the saddle slightly raised. The raised saddle can be used as a handle to push/pull the bike.

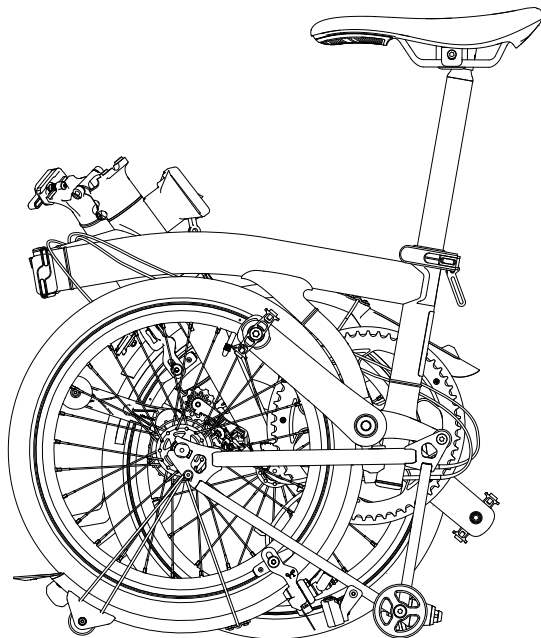

Fig. 4

REMOVING THE LOCKING BLOCK

To remove the locking block, loosen and remove the screw that sits inside the locking block using a 4mm hex key (fig. 1), and then slide the locking block out.