

ADVANCE 4-SPEED GEARING

IMPORTANT INFORMATION

- The 4-speed shifter should only be used with the 4-speed derailleur
- This shifter is not compatible with pre 2017 M/H Type bars or brake levers
- It is impertive that the drive chain, cassette and derailleur are cleaned and lubricated frequently to retain optimal function
- If you are unsure of the correct fitting process please consult your Brompton dealer or Brompton Customer Service support@brompton.co.uk

USING THE SHIFTER

The 4-speed shifter uses a self-returning lever to change between the four gears. Pushing it down with your thumb will shift into an easier gear and flicking the lever upwards will shift into a harder gear (fig.1). It is advised that each individual gear is changed while pedalling for smoother shifting or to avoid damaging the relating components. The indicator window will give an indication of which gear is selected (fig. 1, 2).

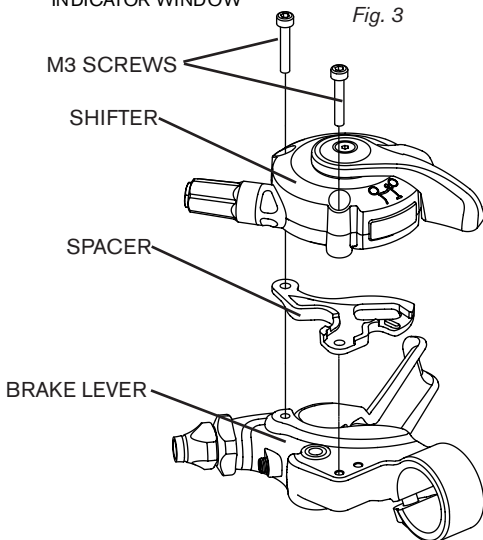
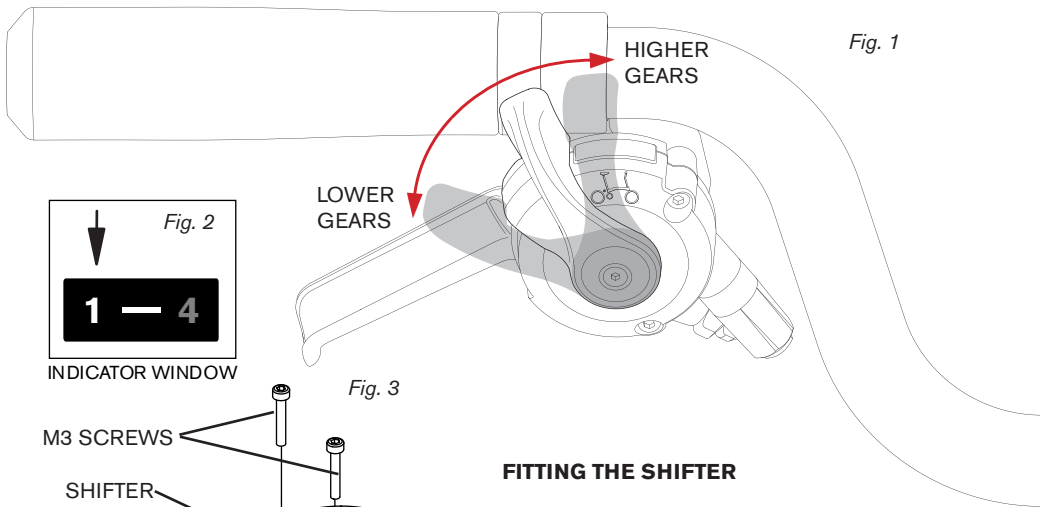

FITTING THE SHIFTER

The shifter mounts directly to the left hand brake lever, it is held in place by two M3 screws. These should be tightened to **0.6Nm**. Do not overtighten the screws as this can reduce the performance of the shifter and damage the parts.

As standard a spacer (fig. 3) is fitted between the shifter and brake lever. This spacer is vital to ensure clearance between the shift lever and the grip.



MAINTAINANCE

It is vital that the key functional components like the chain, cassette and derailleur are kept clean and lubricated. If these components are kept clean their lifespan will be extended and they will function better. If there is a build up of grease and dirt on the drivetrain, the gearing may not work properly.

ADJUSTMENT

If the gears become louder than normal or start to skip and this is not due to dirt and grime on the parts, it could be due to cable stretch. This is especially common for new bikes or where new cables have been fitted. This can be fixed by adding tension to the cable. **See cable tension instruction below.** The derailleur not being aligned properly could also cause the same issue though this usually affects the highest and the lowest gear. In which case you will need to adjust the two limit screws LS on the outside of the derailleur. **See limit screws instruction below.**

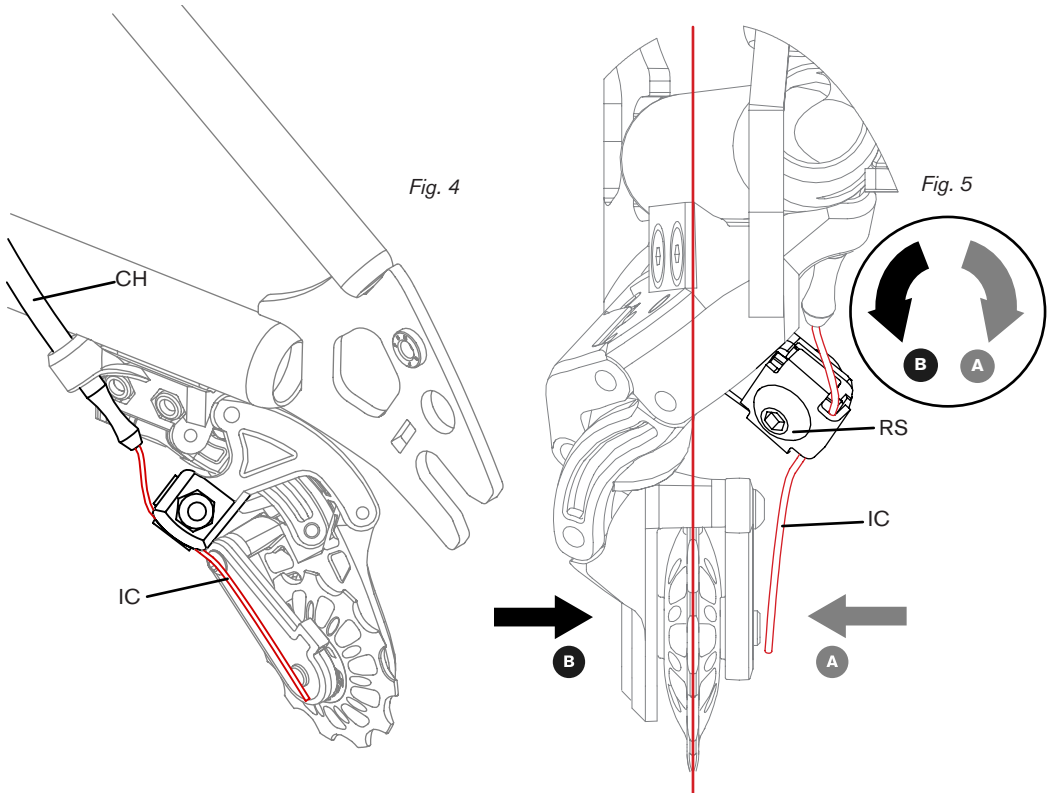

CABLE TENSION

To add tension lost due to cable stretch, place the bike in a stand. Unscrew the barrel adjuster (fig. 7) outwards a quarter turn at a time, each time pedalling the bike whilst listening for the reduction of noise. A visual check can also be done to insure that the jockey wheel on the derailleur is aligned with the selected sprocket on the cassette. If the bike is failing to reach the largest sprocket this means that too much tension has been added screw the barrel adjuster inwards to remedy this issue. (fig. 7). If this doesn't fix the original issue, change to the smallest sprocket on the cassette, then loosen the bolt holding the cable in place on the inside of the derailleur (fig. 4,5). Use a small pliers to pull the inner cable IC end to increase the cable tension and then tighten the bolt RS (fig. 5).



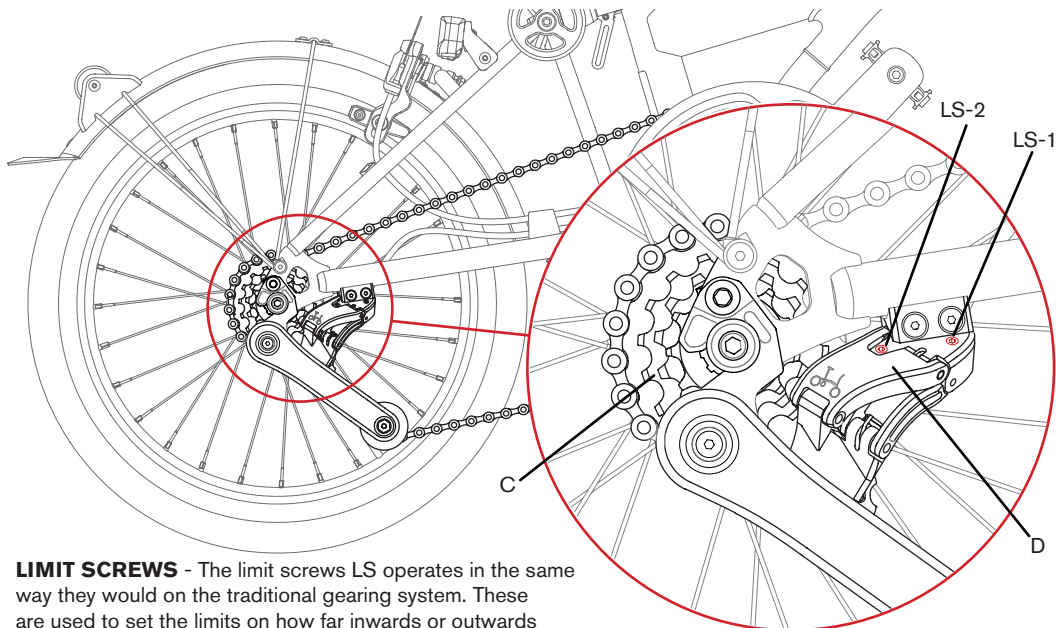

LIMIT SCREWS - The limit screws LS operates in the same way they would on the traditional gearing system. These are used to set the limits on how far inwards or outwards the derailleurs can carry the chain. If there is an issue with reaching the highest or the lowest gear, the limit screw may need adjusting. 2mm hex key is needed for adjusting.

LS-1 is used to create alignment on the largest sprocket on the cassette. **LS-2** for the smallest (fig. 5).

FITTING A NEW CABLE

- Screw the barrel adjuster fully clockwise so that it is at its shortest setting, then unscrew by 2 turns
- Select the lowest gear (1) and then press the shift lever downward so it does not obscure the cable entry hole
- Feed the gear cable into the shifter in a slightly downward direction and through the cable bush
- If there is resistance pushing the cable through the bush pull the cable back a little and try again
- Once you can feel the cable pass through the bush keep feeding it until you feel slight resistance
- Keep feeding it through so that it follows around the guide inside the shifter and exits through the barrel adjuster.

DO NOT FORCE THE CABLE AS THIS MAY DAMAGE THE SHIFTER

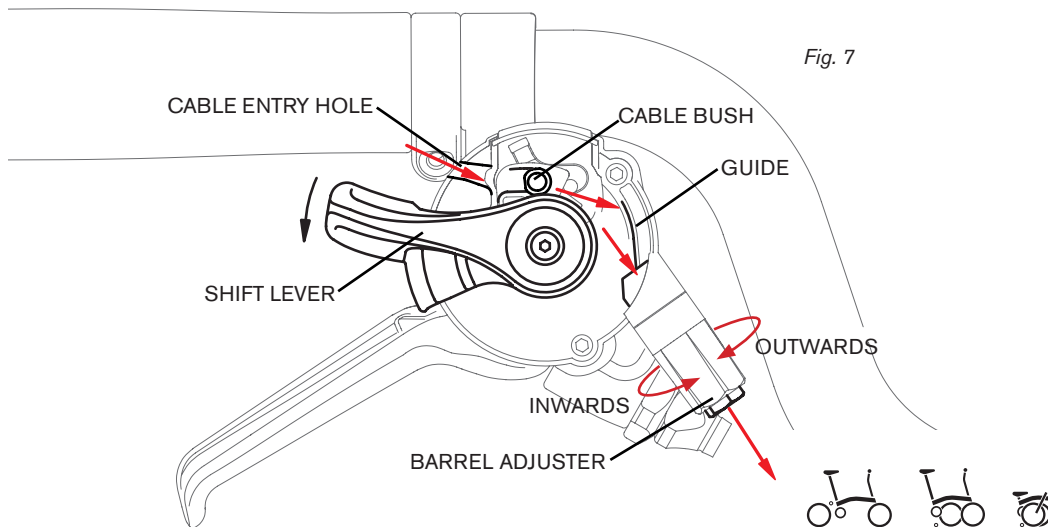

SETTING THE GEARS

- Insert the inner cable IC into the cable housing CH
- Thread it all the way through until it exits through the end of the housing
- Route the cable along the bike frame following the same paths as the existing cables. This is essential for folding
- When the cable reaches the rear frame, route the cable through the stopping block (fig. 8)
- Using some needle nose pliers or similar, pull the cable through the housing and insert into the derailleur
- Tighten the bolt that holds the cable in place on the inside of the derrailleur (fig. 5)
- Use the barrel adjuster on the shifter to make adjustments to the cable tension as needed (fig. 7)
- Unscrewing the adjuster will add more tension to the cable and improve shifting into the lower gear (fig. 7)
- Screwing the adjuster inwards will reduce tension and improve shifting into the high gear
- The jockey wheel on the derailleur needs to be in-line with the selected gear sprocket on the cassette (fig. 5).

Fig. 8

